

# MS3120

Mariner Kit for use with HP Z4 G5 Workstation  
(Tower configuration)



The HP Z4 G5 Workstation is marine type approved by most of the major international marine Classification Societies when it is installed in conjunction with our Mariner Kit MS3120.

The MS3120 Mariner Kit is designed to be installed onto any horizontal surface and affords protection against the effects of vibration and shock experienced in the offshore marine environment and has been tested against IACS Unified Requirement E10 and the relevant sections of IEC60945 (see below right for test details).

This type approved combination of hardware and Mariner Kit can be used as the platform for your critical navigation, control, loading and general purpose applications (please check individual type approval certificates for any restrictions).

**“World leading type approved computer hardware”**



## PRODUCT FEATURES

- ◆ HP's best-selling workhorse, now more powerful. This high-performance workstation does it all
- ◆ The Z4 G5 accelerates workflows across a wide range of professional apps and provides plenty of room to expand as work evolves
- ◆ Get peace of mind with a workstation that's built to endure. The Z4 G5 undergoes 360K hours of rigorous testing, military-standard testing and is certified for pro apps
- ◆ Designed for simpler IT management, the Z4 G5 is built for longevity with a 3-year lifecycle. Plan for the future and avoid re-qualifying devices every year, saving you serious time and money
- ◆ Power demanding professional workloads with up to 20 cores in a next-gen Intel® Xeon® W CPU, plus Intel vPro® enhanced manageability and security, and ECC Memory for data reliability
- ◆ With HP Wolf Pro Security get a hardware-enforced, always-on defence. From the BIOS to the browser – above, in, and below the OS – these constantly evolving solutions help protect from modern threats
- ◆ Support your unique user needs with a choice of Windows 11 Pro for Workstations, WSL2 or Linux® operating systems
- ◆ Get serious about graphics and reach peak productivity with access to a breadth of NVIDIA® and AMD professional graphics from entry to mid-range 3D
- ◆ Up to 512GB DDR5 ECC Memory
- ◆ Integrated RJ-45 LAN port (1GbE AMT)
- ◆ Two full-height, full-length PCIe Gen4 x16 slots; One full-height, full-length PCIe Gen5 x16 slot; Two full-height, half-length PCIe Gen4 x4 slots; Two M.2 PCIe Gen4 x4 slots
- ◆ Four front and six rear USB ports
- ◆ ENERGY STAR® certified and EPEAT® Gold registered configurations available
- ◆ Protected by HP Services, including a 1-year parts, 1-year labour, and 1-year onsite service (1-1-1) standard limited warranty

This Mariner Systems solution is tested against the consolidated 'worst-case' requirements of all the following major international marine Classification Societies:

**ABS, BV, CCS, ClassNK, DNV, KR, LR, PRS & RINA**

Tests included within the test programme are as follows:

- > Vibration, Shock, Static and Dynamic Inclination
- > Dry & Damp Heat, Low Temperature
- > Acoustic Noise, Compass Safe Distance
- > High Voltage, Power Supply Variation & Power Supply Failure
- > Conducted LF & RF, Electromagnetic Field
- > Radiated & Conducted Emissions, Electrostatic Discharge
- > Insulation Resistance, Burst / Fast Transients
- > Surge Immunity, Access to Dangerous Voltages

# MS3I20

## Mariner Kit for use with HP Z4 G5 Workstation (Tower configuration)

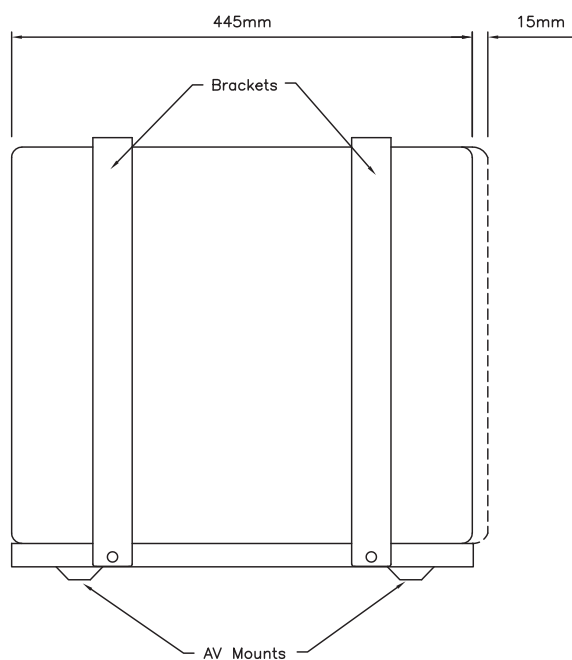
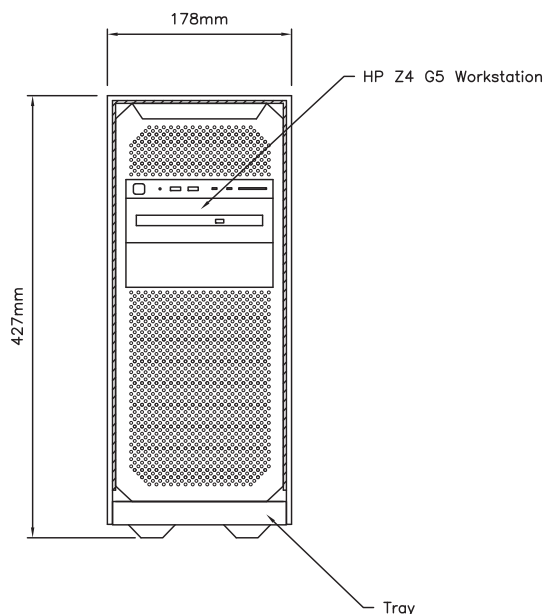

### Mariner Systems (UK) Limited

Oaklands Park • Wokingham • Berkshire • RG41 2FD • United Kingdom  
Telephone: +44 (0) 118 979 6020 • sales@marinersystems.com  
www.marinersystems.com

## OPERATING GUIDELINES

Although all of our solutions are tested against extreme environmental conditions for the purposes of marine type approval, installation should take into account the following guidelines:

- Keep the workstation away from excessive moisture, direct sunlight and the extremes of heat and cold. Wherever possible, ensure that the unit is operated within the manufacturer's recommended operating range:

	Operating	Non-Operating
<b>Temperature</b>	+5° to +40°C (+40° to +104°F)	-40° to +60°C (-40° to +140°F)
<b>Humidity</b>	8% to 85% (non-condensing)	8% to 90% (non-condensing)

- Leave at least a 10.2 cm (4-inch) clearance on all vented sides of the workstation to permit the required airflow
- Never restrict airflow into the workstation by blocking any vents or air intakes
- Occasionally clean the air vents on all vented sides of the workstation
- If the workstation is to be operated within a separate enclosure, intake and exhaust ventilation must be provided on the enclosure, and the same operating guidelines listed above will still apply

By following these guidelines, you will maximise the life of your workstation and minimise service costs.

## STATISTICS

<b>Overall Fitted Dimensions</b>	178mm (w) x 427mm (h) x 460mm (d)
<b>Weight (Mariner Kit only)</b>	2.3 kg
<b>Typical Weight (including hardware)</b>	14.9 kg (exact weight depends upon configuration)
<b>Chipset</b>	Intel® W790
<b>Processor</b>	Intel® Xeon® processors up to and including 4.0GHz (4.8GHz turbo) frequency, 37.5MB cache, 20 cores
<b>Memory</b>	Up to 512 GB DDR5-4800 DIMM
<b>Storage</b>	1 TB to 8 TB 3.5-inch SATA HDD (7,200 rpm); 512 GB to 4 TB Z Turbo TLC / Opal2 TLC SSD; 512 GB to 1 TB Z Turbo Dual Pro TLC SSD; 512 GB to 1 TB Z Turbo Quad Pro TLC SSD
<b>Keyboard</b>	HP USB Keyboard
<b>Mouse</b>	HP USB Mouse
<b>Networking</b>	1 x RJ-45 Integrated LAN Port (1GbE AMT)
<b>Graphics</b>	No integrated graphics (as standard); NVIDIA T400 4GB; NVIDIA T1000 4GB; NVIDIA T1000 / T1000E 8GB; AMD Radeon RX 6400 4GB; AMD Radeon Pro W6600 8GB
<b>Optical Storage</b>	HP 9.5mm Slim DVD-ROM; HP 9.5mm Slim DVD Writer
<b>Operating System</b>	Windows 11 Pro for Workstations; Ubuntu 22.04 LTS; HP Linux Ready; Red Hat® Enterprise Linux®
<b>Expansion Slot</b>	Two full-height, full-length PCIe Gen4 x16 slots; One full-height, full-length PCIe Gen5 x16 slot; Two full-height, half-length PCIe Gen4 x4 slots; Two M.2 PCIe Gen4 x4 slots
<b>Front I/O</b>	Entry: 4 x USB 3.1 Type-A ports (1 charging); Premium: 2 x USB 3.1 Type-A ports (1 charging); 2 x USB 3.2 Type-C ports; SD Reader (optional)
<b>Rear I/O</b>	6 x USB Type-A ports; 1 x RJ-45 LAN Port (1GbE AMT); 1 x Flex I/O Module (optional)
<b>Operating Voltage Range</b>	90 to 269 VAC

Design and specifications are subject to change without notice. E&OE.

Version 1